

product name

High Quality CE Approval Round 11W Ceiling Lamps

product desc

Specifications

Ceiling Lamps

Functional option: Dimmable / CCT tunable/ Humanbody sensor / Acoustic & Light Sensor / Microwave Sensor

High Quality CE Approval Round 11W Ceiling Lamps

Ceiling lamps features:

- 1.High efficiency,save more than half energy than traditional lights;
- 2.Constant current drive,no flicker, no electromagnetic rad
- 3.Long lifespan:35,000 hrs,low lumens decline
- 4.Functional option: Dimmable / CCT tunable/ Humanbody sensor / Acoustic &

Light Sensor / Microwave Sensor

Ceiling lamps application:

Widely applied to

household, office, hotel, school, hospital and other places needing energy saving and longtime lighting.

1. Instead of the indoors ceiling light
2. School/Universities/Hospital
3. Conference/Meeting room, Show room
4. Commercial Complexes
5. Factories/Offices
6. Super-markets
7. Residential/Institution buildings



Ceiling lamps assembly:

Surface mounted on ceiling floor with three screw nails first, then cover the mask, easy to disconnect.

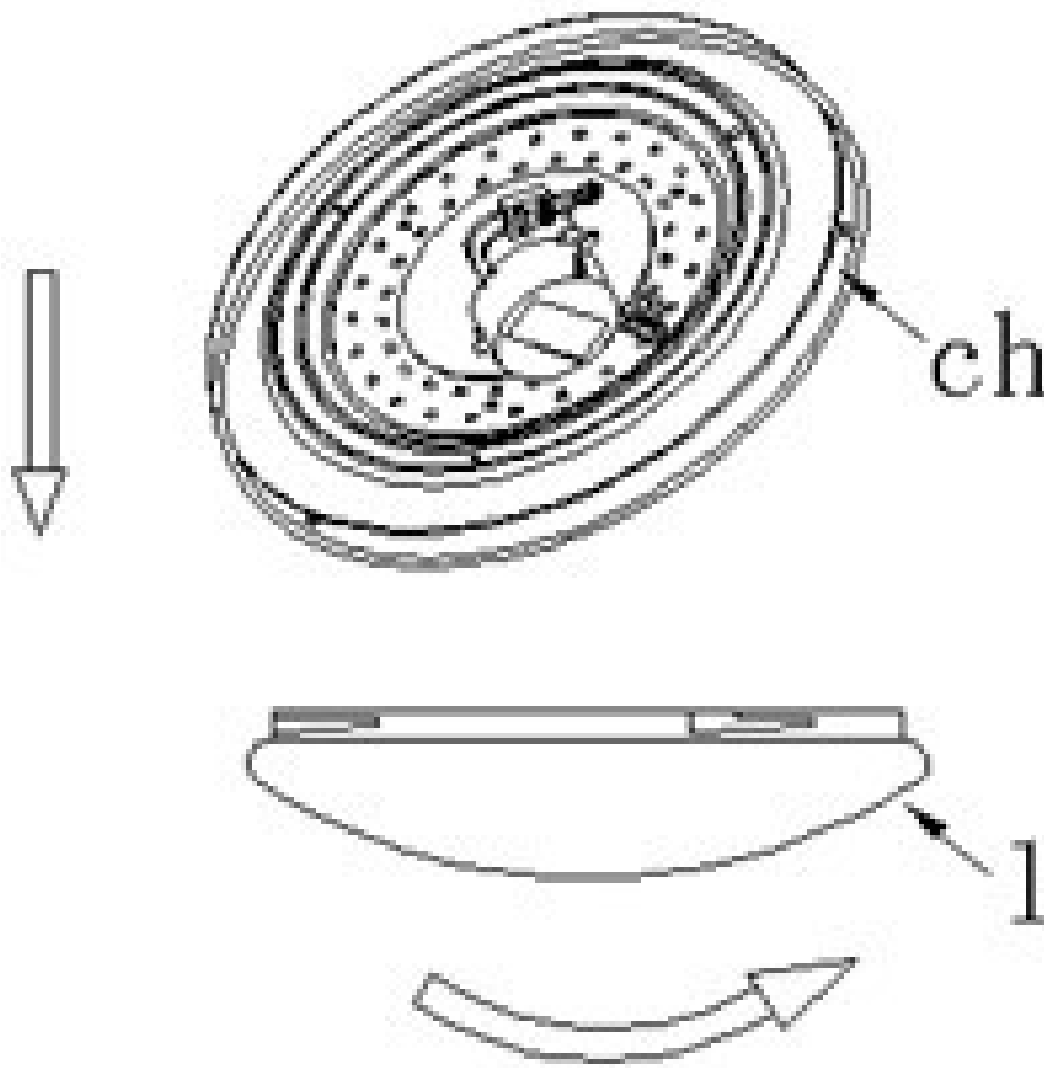

Fig. 1

Fixture Holes

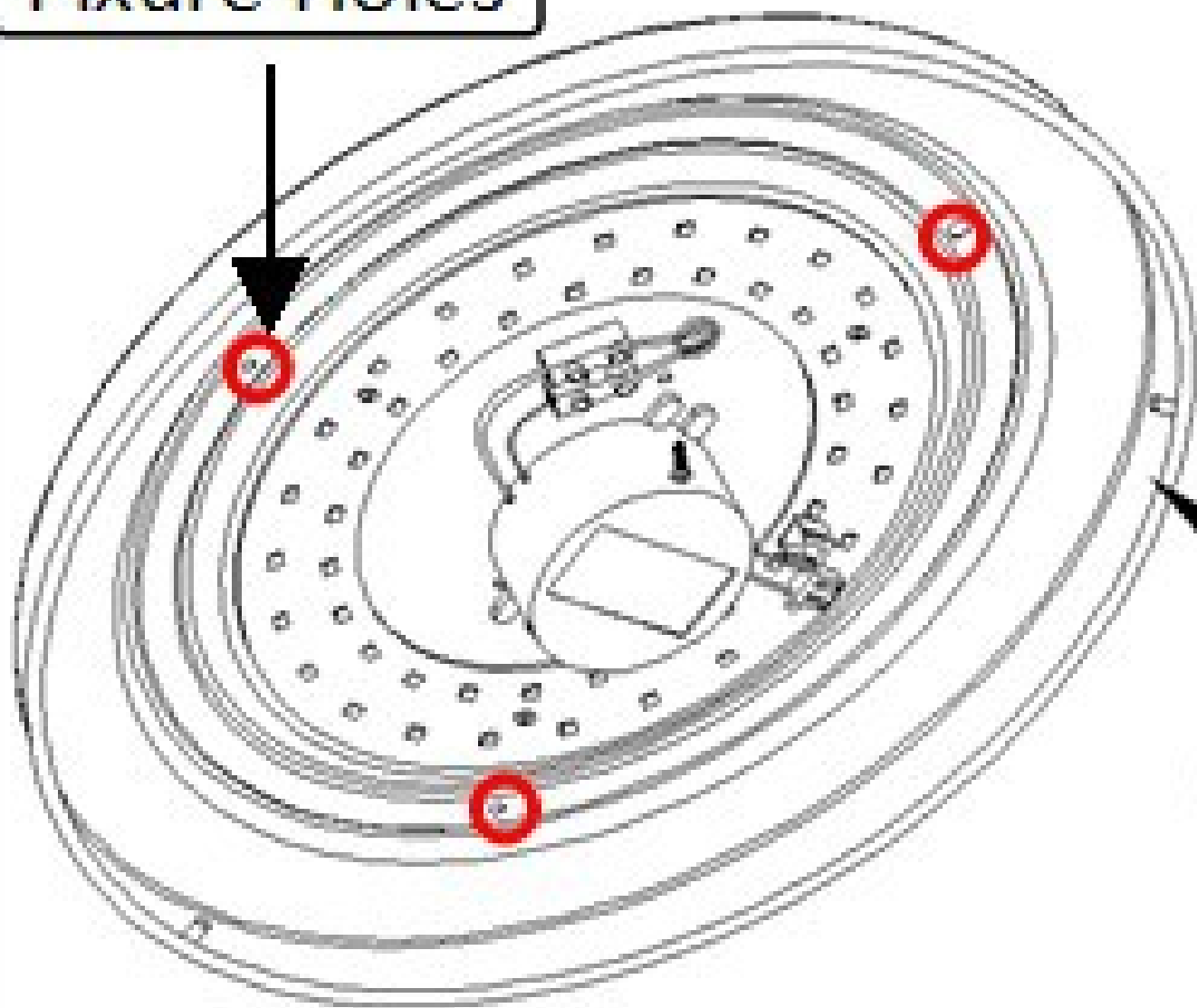

Fig. 2

Main Power
Cable Hole

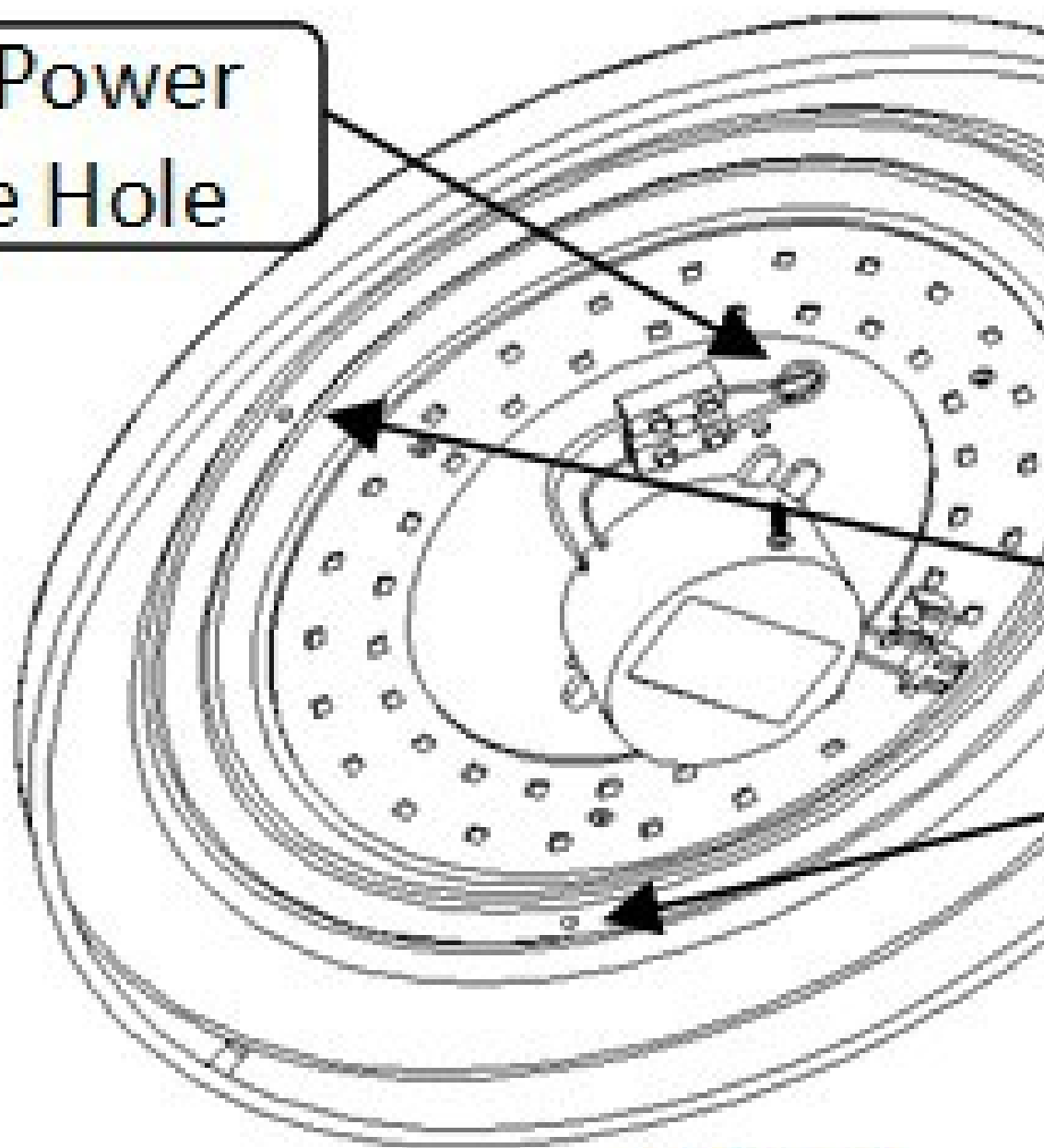
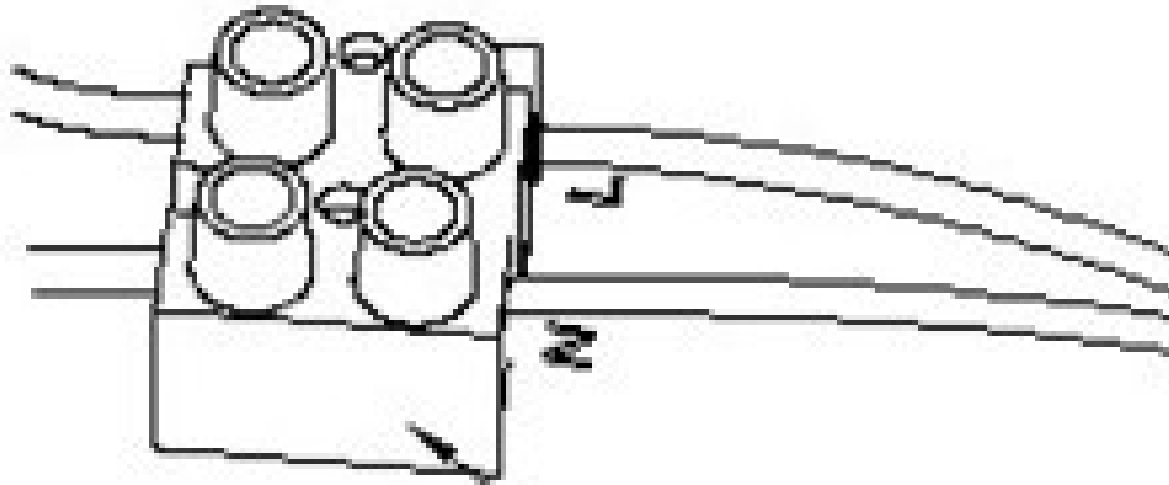

Fig. 3



Connector

Fig. 4

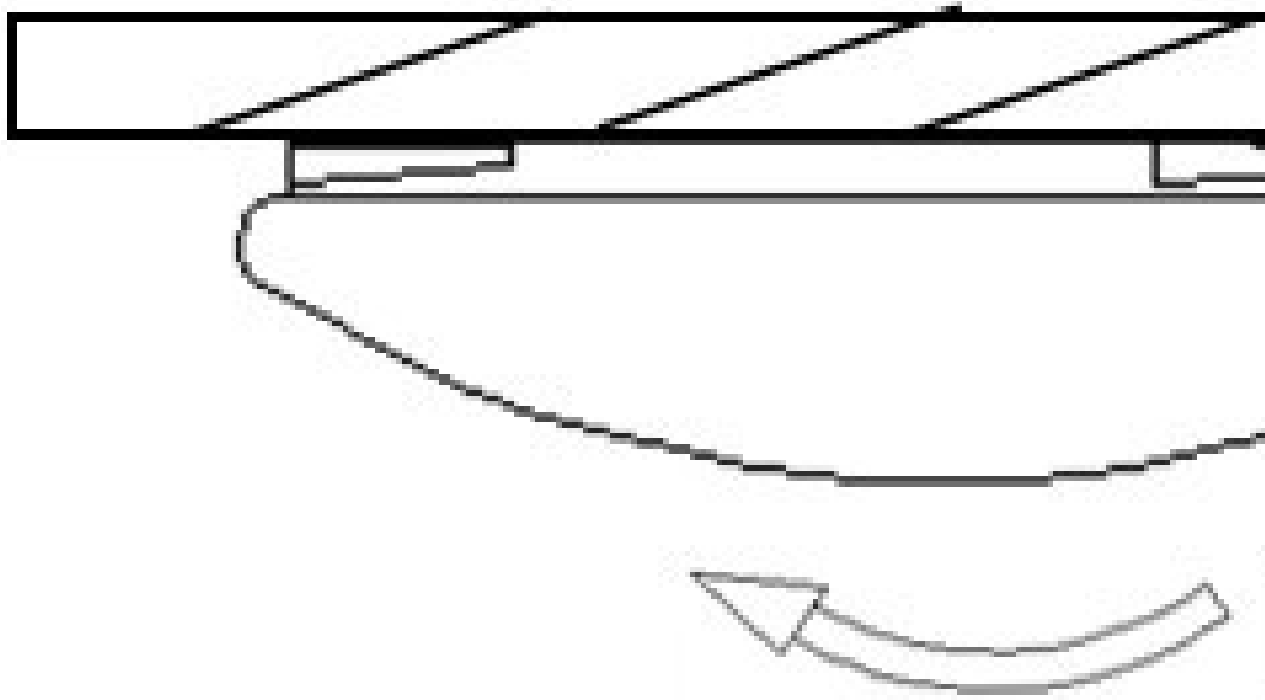

Fig. 5

Ceiling lamps package:

Description of Goods	Specification	QTY (PCS)	P
LED round ceiling light 11W	GPX1301112	6	



Why GOPRO

Established in 1994, Xiamen Guangpu Electronics Co., Ltd. is one of the earliest LED factories in China, with 20 years' experience in LED encapsulation and development, manufacturing its application products, like ceiling lamps.



Our company passed ISO9001:2008, UL, TS16949 quality system and all products comply with EU RoHS and WEEE standard. Excellent quality and high reputation makes us to be the good supplier of international renowned enterprises and attracts good business partners.

Our products have been exported to South-East Asia, Japan, Europe and America and are very popular among these areas.

1. 20 years experience on LED manufacturing
2. Establish long term stable cooperation with many renowned enterprises
3. Professional technology team, more than 200 R&D personnels
4. Self-reliant in LED light source
5. Strict procedure quality supervising and burn-in period
6. Complete Quality Control System
7. Good after-sales service